

Dimension Information - 4-Door Fig 1: Complete Underbody 1995 Land Rover RangeRover

PLEASE SEE "HOW TO USE DIMENSION INFORMATION" SECTION

2746 (108 1/8) WHEELBASE

Dimensions from Centerline are Combined When Equal  
Divide by 2 for Individual Dimensions from Centerline  
All Bolts and Holes are Measured to Center  
Unless Otherwise Described in "Measuring Points"

BOTTOM VIEW

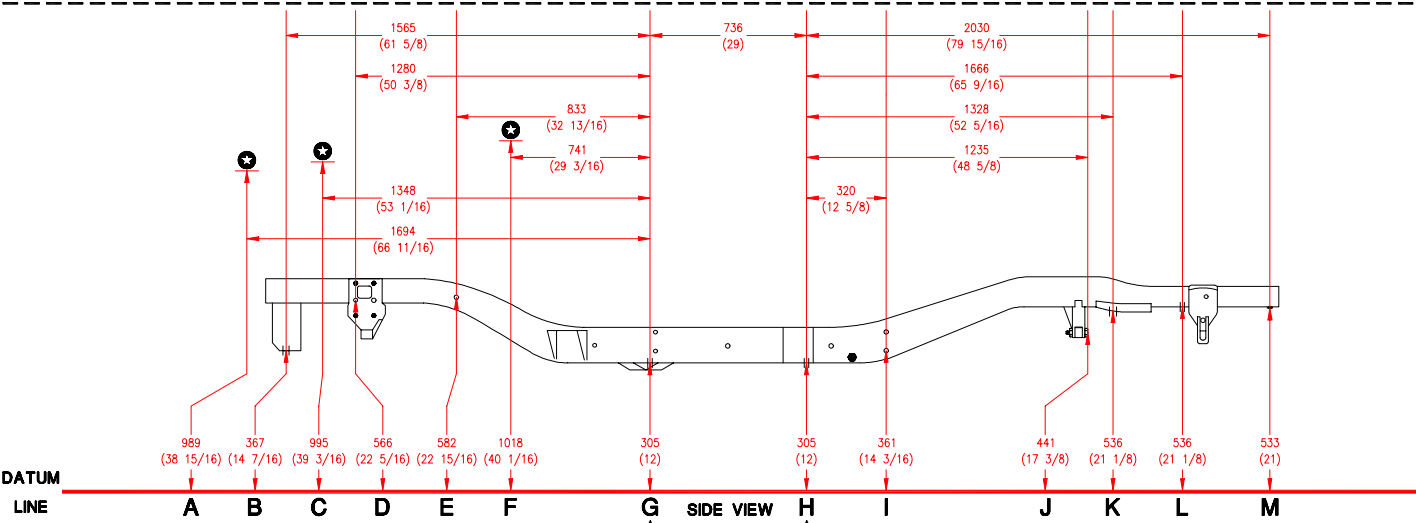
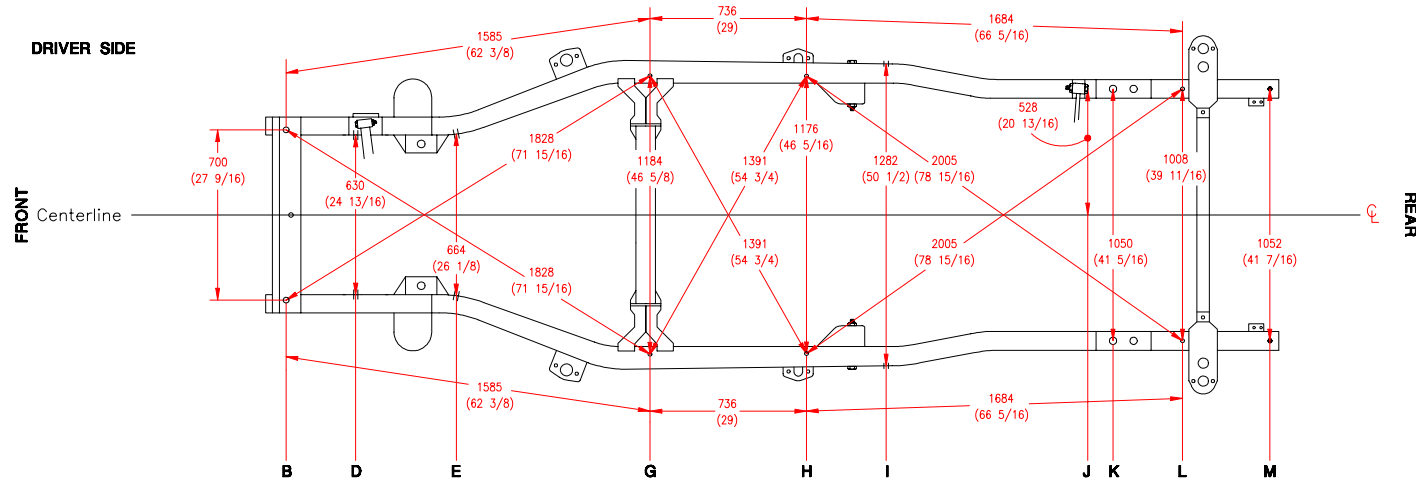

MEASURING POINTS

- A** - Head of Core Support Bolt
- B** - Center of 15 (9/16) Hole
- C** - Head of Front Fender Bolt
- D** - Center of 12 (1/2) Hole
- E** - Center of 12 (1/2) Hole
- F** - Head of Hood Hinge Front Bolt
- G** - Center of 13 (1/2) Hole
- H** - Center of 13 (1/2) Hole
- I** - Center of 13 (1/2) Hole
- J** - DS - Head of Bolt - Panhard Rod
- K** - Center of 20 (13/16) Hole
- L** - Center of 14 (9/16) Hole
- M** - Head of Bolt - Bumper

- DS** - DRIVER SIDE
- PS** - PASSENGER SIDE

- - BOLTS
- - RIVETS
- - HOLES
- - DATUM LINE ZERO POINT
- ▲ - LOWER BALL JOINT - LOADED
- ★ - LOWER BALL JOINT - UNLOADED
- ☆ - WIDTH DIMENSION ON ENGINE COMPARTMENT VIEW - SEE BACK OF PAGE

- frm** - MEASUREMENT TO SURFACE OF FRAME (PARTS REMOVED)
- bolt** - MEASUREMENT TO BOLT

